

# SIQR MODEL FOR TRANSMISSION OF LASSA FEVER CONTROL DYNAMICS

by

**M.U. Sarki, S.H. Isah, R.B. Akpeoshe, U.M. Ma'aji, H.B. Labaran**

*Faculty of Natural and Applied Sciences, Nasarawa State University, PMB 1022 Keffi. & Department of Biological Science, Rabiu Musa College of Advance and Remedial Studies, Kano.*

*Corresponding Author: [musarki@nsuk.edu.ng](mailto:musarki@nsuk.edu.ng)*

## Abstract

*In this article, SIQR model is proposed, the transmission of Lassa fever control dynamics is analyzed and studied using stability theory of differential equations at both theoretical level and using numerical simulation, the sufficient conditions for disease free equilibrium is obtained. The infection-free stability is investigated. Using Jacobian matrix approach. It is shown that the introduced quarantine parameter helps in controlling and eradication of the Lassa fever virus in the population with respect to time. The analysis further reveals that the disease can be controlled if the basic reproduction number  $R_0$  is less than one regardless of the initial population.*

**Keywords:** *SIQR model, quarantine parameter, disease free equilibrium, numerical simulation.*

## Introduction

The greatest threat to human is infection diseases, the outbreak of infection diseases has caused the loss of millions of lives, great pain to families and also involves expenditure of huge amount of money in controlling the disease. The whole world has devoted efforts to control the spread of diseases. Mathematical models which describe the dynamics of infectious diseases have recently become important tools in analyzing the spread and control of infectious diseases [1,2,3,4]. Many mathematical models have already been proposed and studied to investigate the transmission and control of the dynamics of infectious diseases, these models provides the theoretical and quantitative bases for the prevention and control of infectious diseases [1].

Lassa fever is a form of such infectious diseases, it is an acute viral hemorrhagic fever (VHF) caused by the Lassa virus which is endemic in the belt of West Africa (Nigeria, Guinea Liberia, Sierra Leone) affecting about 2 – 3 million persons with 5,000 - 10,000 fatalities annually [5,6,7]. Transmission to Man occurs from exposure to excreta and blood of the rat, eating of contaminated food and water, or eating the rat as food. There may also be transmissions due to seasonal variations [6,8]. Infections also occur through contact with the fluid from an infected person [7,8,10]. Since its initial discovery in Lassa-Nigeria, outbreaks of Lassa fever have occurred repeatedly in other parts of Nigeria [9].

Lassa fever outbreaks in endemic areas are increased by factors that promote activities of man to rodents which include poor sanitation, crowding, deforestation, bush burning, rodent hunting and some other Agricultural activities [11].

In this article we study and formulate susceptible-infectious-quarantine-recovered (SIQR) model for the transmission and control dynamics of Lassa fever.

The schematic description of our model is given in the figure below

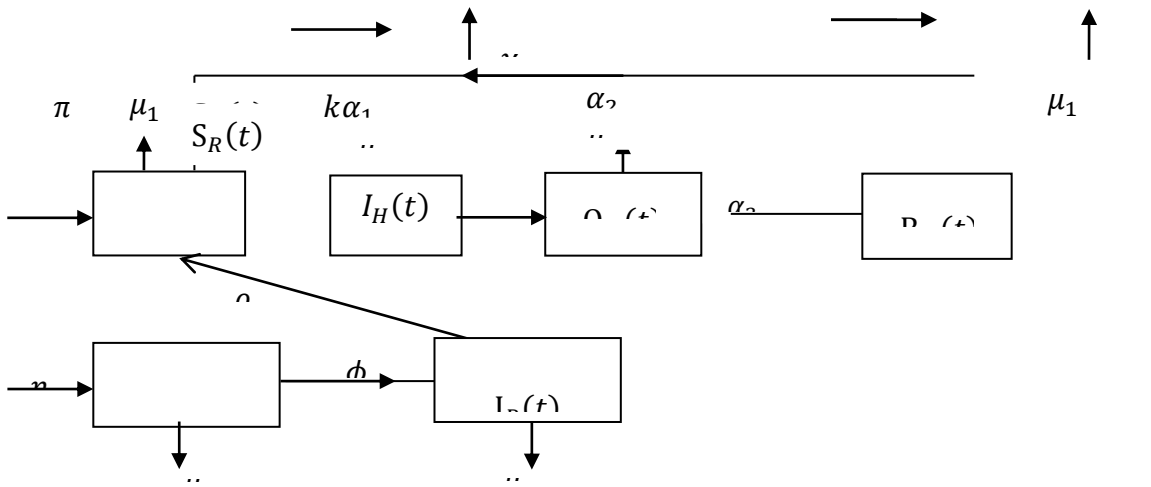

**Fig. 1:** Flow diagram of the dynamics Lassa Fever with Quarantine

**2.0 Model Formulation**

Lassa fever models usually encompassed individuals who have not come into contact with the virus known as susceptible humans ( $S_H(t)$ ). The susceptible rodents ( $S_R(t)$ ) become infected at the rate  $\phi$  and infectious rodent infects human at the rate  $\rho$ , the infected human are treated at the rate  $\delta$ , while some moved to the quarantine human class ( $Q_H(t)$ ) at the rate  $\alpha_2$ . Those who are not aware of the treatment will be removed from the population through death at the rate  $\alpha_3$ , While the quarantine human class return to the susceptible human class at the rate  $\gamma_1$ , The existence of region where the model is epidemiologically feasible is established. Stability analysis of the disease free equilibrium is investigated through the reproduction number obtained using the next generation operator approach.

In this model, individuals are recruited into the susceptible population of human at the rate  $\pi$ , susceptible population of rodent at the rate  $\eta$ , The infection spread at the rate  $k$ , where  $k$  is the probability of getting Lassa fever,  $c$  is the contact rate, both human and rodent die naturally at the rate  $\mu_1$  and  $\mu_2$  respectively.

The total population of human and Rodent are given by

$$N_H(t) = S_H(t) + I_H(t) + Q_H(t) + R_H(t) \text{ and } N_R(t) = S_R(t) + I_R(t) \text{ respectively.}$$

$N(t) = N_R(t) + N_H(t) =$  Total population size at

$$\frac{dS_H}{dt} = \pi + \rho I_R + \gamma_1 R_H - k\alpha_1 S_H - \mu_1 S_H \tag{1}$$

$$\frac{dI_H}{dt} = k\alpha_1 S_H - (\mu_1 + \alpha_2 + \omega) I_H \tag{2}$$

$$\frac{dQ_H}{dt} = \alpha_2 I_H - (\mu_1 + \alpha_3) Q_H \tag{3}$$

$$\frac{dR_H}{dt} = \alpha_3 Q_H - (\mu_1 + \gamma_1) R_H \tag{4}$$

**For the Rodent Populations:**

$$\frac{dS_R}{dt} = \eta - (\mu_2 + \phi) S_R \tag{5}$$

$$\frac{dI_R}{dt} = \phi S_R - (\mu_2 + \rho) I_R \tag{6}$$

With initial conditions

$$S_H(t) > 0, I_H(t) > 0, Q_R(t) > 0, R_H(t) = 0, S_R(t) > 0, I_R(t) > 0.$$

$$\text{The force of the infection } k = \frac{\beta c I_H}{N}$$

$$\left. \begin{aligned} N_H(t) &= S_H(t) + I_H(t) + Q_R(t) + R_H(t) \\ N_R(t) &= S_R(t) + I_R(t) \end{aligned} \right\} \quad (7)$$

$$N(t) = N_H(t) + N_R(t) \quad (8)$$

### Existence of Disease Free Equilibrium (DFE) $E_f$

In the absence of the disease, it implies that  $I_H(t) = 0, Q_R(t) = 0, R_H(t) = 0, I_R(t) = 0$ .

Therefore the above system of equations is reduced to

$$\frac{dS_H}{dt} = \pi - k\alpha_1 S_H - \mu_1 S_H \quad (9)$$

$$\frac{dS_R}{dt} = \eta - (\mu_2 + \phi) S_R \quad (10)$$

Hence letting equation (9) and (10) to zero and solving them simultaneously, we get

$$S_H = \frac{\pi}{\mu_1}, S_R = \frac{\eta}{\mu_2 + \phi},$$

Hence,

$$E_f = (S_H, I_H, Q_H, R_H, S_R, I_R) = \left( \frac{\pi}{\mu_1}, 0, 0, 0, \frac{\eta}{\mu_2 + \phi}, 0 \right) \quad (11)$$

### Computation of the Basic Reproductive Number ( $R_0$ ) of the Model

The basic reproductive number ( $R_0$ ) is define as the number of secondary infections that one infectious individual would create over the duration of the infectious period, provided that everyone else is susceptible.  $R_0=1$  is a threshold below which the generation of secondary cases is not sufficient to maintain the infection in human community. If  $R_0 < 1$ , the number of infected individuals will decrease from generation to next and the disease dies out and if  $R_0 > 1$  the number of infected individuals will increase from generation to the next and the disease will persist.

We first rearranged the model Eqs (1) – (7) beginning with the infective classes to obtain the following equations below:

$$\frac{dI_H}{dt} = k\alpha_1 S_H - (\mu_1 + \alpha_2 + \omega) I_H \quad (12)$$

$$\frac{dI_R}{dt} = \phi S_R - (\mu_2 + \rho) I_H \quad (13)$$

$$\frac{dQ_H}{dt} = \alpha_2 I_H - (\mu_1 + \alpha_3) Q_H \quad (14)$$

$$\frac{dR_H}{dt} = \alpha_3 Q_H - (\mu_1 + \gamma_1) R_H \quad (15)$$

$$\frac{dS_R}{dt} = \eta - (\mu_2 + \phi) S_H \quad (16)$$

$$\frac{dS_H}{dt} = \pi + \rho I_R + \gamma_1 R_H - k\alpha_1 S_H - \mu_1 S_H \quad (17)$$

To compute the basic reproductive number ( $R_0$ ) of the model Eqs (1) – (7), we employ the next generation method as applied in [3]. Using the approach in [3] we have

$$\mathcal{F}_i = \begin{pmatrix} \frac{\beta c \alpha_1}{N} I_H S_H \\ 0 \\ 0 \\ 0 \\ 0 \\ 0 \end{pmatrix} \quad (18)$$

$$\mathcal{V}_i = \begin{pmatrix} \frac{\beta c \alpha_1}{N} I_H S_H \\ 0 \\ 0 \\ 0 \\ 0 \\ 0 \end{pmatrix} \quad (19)$$

Where  $\mathcal{F}_i$  and  $\mathcal{V}_i$  are the rate of appearances of new infections in compartment  $i$  and the transfer of individuals into and out of compartment  $i$  by all other means respectively. Using the linearization method, the associated matrices at disease-free equilibrium ( $E_0$ ) and after taking partial derivatives as defined by

$$D\mathcal{F}_i(E_0) = \begin{pmatrix} F & 0 \\ 0 & 0 \end{pmatrix} \text{ and } D\mathcal{V}_i(E_0) = \begin{pmatrix} V & 0 \\ J_3 & J_4 \end{pmatrix}$$

Where  $F$  is non-negative and  $V$  is a non-singular matrix, in which both are the  $m \times m$  matrices defined by

$F = \left[ \frac{\partial \mathcal{F}_i}{\partial x_j}(E_f) \right]$  and  $V = \left[ \frac{\partial \mathcal{V}_i}{\partial x_j}(E_f) \right]$ , with  $1 \leq i, j \leq m$  and  $m$  is the number of infected classes. In particular  $m = 3$ , we have

$$f_i = \begin{pmatrix} k \alpha_1 S_H \\ 0 \\ 0 \end{pmatrix} \quad (20)$$

$$v_i = \begin{pmatrix} (\mu_1 + \alpha_2 + \omega) I_H \\ -\phi S_R + (\mu_2 + \rho) I_H \\ -\alpha_2 I_H + (\mu_1 + \alpha_3) Q_H \end{pmatrix} \quad (21)$$

$$F = \begin{pmatrix} \frac{\beta c \alpha_1 \pi}{\mu_1 N} & 0 & 0 \\ 0 & 0 & 0 \\ 0 & 0 & 0 \end{pmatrix} \quad (22)$$

$$V = \begin{pmatrix} (\mu_1 + \alpha_2 + \omega) & 0 & 0 \\ 0 & (\mu_2 + \rho) & 0 \\ -\alpha_2 & 0 & (\mu_1 + \alpha_3) \end{pmatrix} \quad (23)$$

and inverse of  $V$  is given such that

$$|FV^{-1} - \lambda| = \begin{vmatrix} \frac{\beta c \alpha_1 \pi}{\mu_1 N (\mu_1 + \alpha_2 + \omega)} - \lambda & 0 & 0 \\ 0 & -\lambda & 0 \\ 0 & 0 & -\lambda \end{vmatrix} = 0 \quad (24)$$

And characteristics polynomial of Eq. (24) is given as



$$\frac{dI}{dt} = -\left(\beta I + \gamma - \frac{\beta I Q}{N} + \mu + \omega + \rho + \phi\right) \quad (37)$$

where,

$$\begin{cases} \beta = (\beta_1 + \beta_2 + \beta_3), \gamma = (\gamma_1 + \gamma_3) \\ \mu = (\mu_2 + \mu), \omega = (\omega_2 + \omega), \rho = (\rho_1 + \rho) \end{cases} \quad (38)$$

### 3.0 Numerical Simulations of the Experiments Model

In order to verify the theoretical predictions of the model, the numerical simulation of the Lassa fever dynamics control model incorporating quarantine class Eqs. (1)–(6) was solved numerically using Runge-Kutta-Fehlberg 4-5th order method and implemented using Maple 17 Software.

The parameters used in the implementation of the model are given by [13,14] as

**Variables:**  $\beta_1(t) = 0.017$ ,  $\beta_2(t) = 0.0087$ ,  $I_H(t) = 0.000014$ ,  $I_R(t) = 0.007$ ,  $R_H(t) = 0.00002$ ,  $Q_H(t) = 0.000001$ .

**Parameters:**  $\pi = 0.0000215$ ,  $\mu_1 = 0.00000548$ ,  $\beta_2 = 0.00000213$ ,  $\alpha_1 = 0.03$ ,  $\alpha_2 = 0.08$ ,  $\alpha_3 = 0.77$ ,  $\omega = 0.01$ ,  $\rho = 0.00005$ ,  $\phi = 0.06$ ,  $\eta = 0.05$ ,  $c = 0.00018$ ,  $\gamma_1 = 0.52$ .

#### List of Numerical Experiments

- (1) The effect of treatment  $\omega$  on the infected population when the quarantine rate is constant
- (2) The effect of quarantine rate on the infected population when contact rate is constant.
- (3) The effect of quarantine rate on the infected population with treatment rate when contact rate is constant
- (4) The effect of quarantine rate on the recovered population contact rate is constant.

**Experiment 1:** The effect of treatment  $\omega$  on the infected population when the quarantine rate is constant

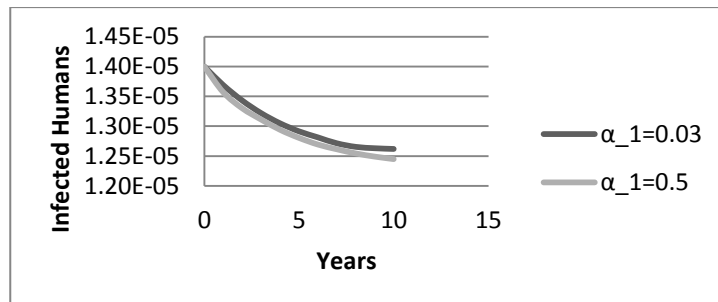

**Fig.2** Graph showing the effect of treatment  $\omega$  on the infected population at low and high ( $\beta_1 = 0.017$ ,  $\beta_2 = 0.0087$ ,  $\beta_3 = 0.00000213$ ) when the contact rate is constant.

**Experiment 2:** The effect of quarantine rate on the infected population when contact rate is constant

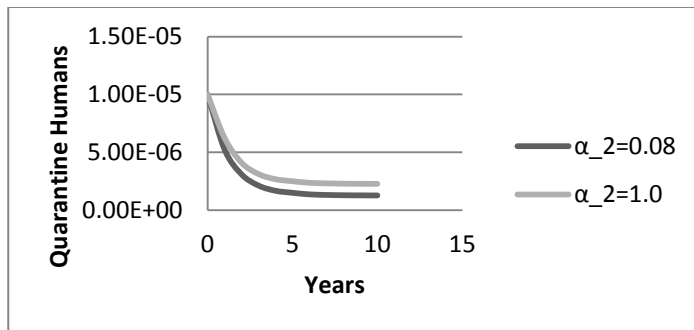

**Fig.3** Graph showing the effect of quarantine on the infected population, when the quarantine rate is constant ( $\beta_1 = 0.0001$ ,  $\beta_2 = 0.0001$ ,  $\beta_3 = 0.0001$ )

**Experiment 3:** The effect of quarantine rate and treatment rate on the infected population when contact rate is constant

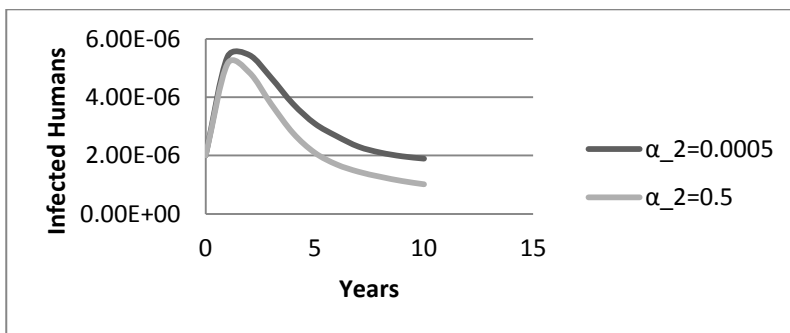

**Fig.3** Graph showing the effect of quarantine and treatment rate, when the quarantine rate is constant ( $\beta_1 = 0.0001$ ,  $\beta_2 = 0.0001$ ,  $\beta_3 = 0.0001$ )

**Experiment 4:** The effect of quarantine rate on the recovered population contact rate is constant

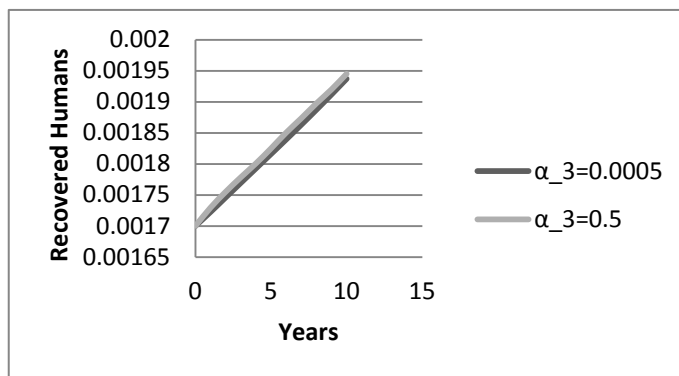

**Fig.5:** Graph showing the effect of quarantine rate on recovered population when the quarantine rate is constant ( $\beta_1 = 0.0001$ ,  $\beta_2 = 0.0001$ ,  $\beta_3 = 0.0001$ )

## Conclusion

In this article, a new mathematical model which incorporated some important factors that plays significant role in the control of Lassa fever was developed. These factors are disease induced death rate and the quarantine parameter. The introduced quarantine parameter helps in controlling and eradication of Lassa fever virus with respect to time. Furthermore, the basic reproduction numbers  $\square_0$  was calculated using the next generation approach. The analysis reveals that the disease can be control if the basic reproduction number  $\square_0$  is less than one regardless of the initial population profile. Thus, every effort must be put in place by all concerned to prevent the virus infection by reducing  $\square_0$  strictly to less than unity.

## References

- Yanli Ma, JiaBao-Liu &Haixia Li, Global dynamics of an SIQR Model with Vaccination and Elimination Model Hybrid Strategies, *Mathematics*, 2018,6, 38; <https://doi.org/10.3390/math6120328>.
- NidhiNirwani, V.H. Badshah& R. Khandelwal, Dynamical Study of SIQR Model with Saturated Incidence Rate, *Nonlinear and Differential Equations*,2016, 4:1;43-50.
- Diekmann. O., Heesterbeek, J.A.P. & Metz. J.A.J., On the Definition and the Computation of the Basic Reproduction Number in Models of Infectious Diseases in Heterogeneous Populations,*J. Math. Biol.*, 1990, 28: 365-382.
- Zhongwei Cao &Shengjuan Zhou, Dynamical Behaviours of Stochastic SIQR Epidemic Model with Quarantine-Adjusted Incidence,*Discrete Dynamics in Nature ad Society*, 2018,1-13. <https://doi.org/10.1155/2018/3693428>.
- Tara. H. Global stability of a delayed SIR epidemic model with density dependent birth and death rates. *Journal of Computational and Applied Mathematics*, 2004, 201: 339–347.
- Dahmanee, A et al, Constrants in the Diagnosis and Treatment of Lassa Fever and The Effect on Mortality in Hospitalized Children and Women with Obsteric Conditions in a Rural District Hospital in Sierra Leone,*Trans R sac Med Hyg*, 2014; 108:126-132. <https://10.1093/trstmh/tru009>.
- McCormick J B, Webb P A, Krebs J W, Johnson K M, Smith E. S, A prospective study of the Epidemiology and Ecology of Lassa Fever. *J Infect Dis*.1987, 155:437- 444.
- Asogun D.A., Adameh, D.I., Ehimun J, Molecular Diagnostic for Lassa Fever at Irrua Specialist Teaching Hospital, Nigderia: Lessons Learnt from Two Years Laboratory, *PloSNegl Trop Dis*, 2012; e1839.
- Tomori, O. A. Fabiyi, A. Sorungbe, A. Smith, & J.B. McCormick, Viral Hemorrhagic Fever Antibodies in Nigerian Populations, *American Journal of Tropical Medicine Hygiene*, 1988, 38: 407–410.
- Omeh, D.J., Achinge, G.I., Echekwube, P.O., Lassa Fever in West Africa: A Clinical and Epidemiological Review, *Journal of Advances in Medicine and Medical Research*, 2017, 24(6):1-12.
- Omeh, D.J., Achinge, G.I., Echekwube, P.O, *Journal of Advances in Medicine and Research*, 2017, 24(6):1-6.
- Omale D &Edibo Thomas E.,. Mathematical Models for Lassa Fever Transmission with Control Strategies. Computing, Information Systems, *Development Informatics & Allied Research Journal*, 2016: 6(4); 1-12.
- Olaniyi S., &Obabiyi O. S, Mathematical Model for Malaria Transmission Dynamics in Human and Mosquito Populations with Nonlinear Forces of Infection,*International Journal of Pure and Applied Mathematics*, 2013:88(1); 125-156.